



## Contract / Terms and Conditions

### Contents

1. Introduction to your Terms and Conditions
2. Queries regarding your Terms and Conditions
3. Diagram of what we cover
4. Definitions
5. General Conditions that apply to all Agreements
6. General Conditions – Cancellation
7. General Exclusions that apply to all Agreements
8. Care Agreements
  - 8.1 Bronze Care
  - 8.2 Bronze Care Exclusions
  - 8.3 Silver Care
  - 8.4 Silver Care Exclusions
  - 8.5 Gold Care
  - 8.6 Gold Care Exclusions
  - 8.7 Platinum Care
  - 8.8 Platinum Care Exclusions
9. Service Only Cover
  - 9.1 Service Only Cover Exclusions
10. Home Electrics Cover
  - 10.1 Home Electrics Cover Exclusions
11. Landlord Assistance
  - 11.1 Landlord Gas Safety Certificate Cover
  - 11.2 Landlord Gas Safety Certificate Cover Exclusions
  - 11.3 Landlord Electrical Inspection Cover
  - 11.4 Landlord Electrical Inspection Cover Exclusions
12. Care and Cover Agreements
13. Using Personal Information
14. Other Products and Services
  - 14.1 Power Flush
  - 14.2 System Filters and Scale Reducers
  - 14.3 Condensate Pipe Kits
15. Frequently Asked Questions
16. Complaints
17. Acceptance of Terms and Conditions of Care/Cover Agreement

### 1. Introduction to your Terms and Conditions

These products have been designed to provide a safe, high quality service to “repair” or “maintain and repair” the elements included in your Agreement. It is important you read carefully these Terms and Conditions together with your Statement confirming the products you hold, as these form the basis of your Agreement with us. If anything is not correct on your Statement, or if you have any questions, please call us on 0800 4087 911. Customers can choose to hold our products as part of a Care Agreement, or individually as separate Cover Agreements. Please see your Statement for confirmation of the products you hold.

### 2. Queries regarding your Terms and Conditions

We hope that you will find the format clear and easy to follow. If you have any questions, please contact us on 0800 4087 911. All Agreements (both Care and Cover) are renewable annual contracts. The cancellation charge section is to give clarity to the charges you may be required to pay for cancelling your Agreement if we have carried out works/repairs during that Period of Agreement.



### 3. Diagram of what we cover

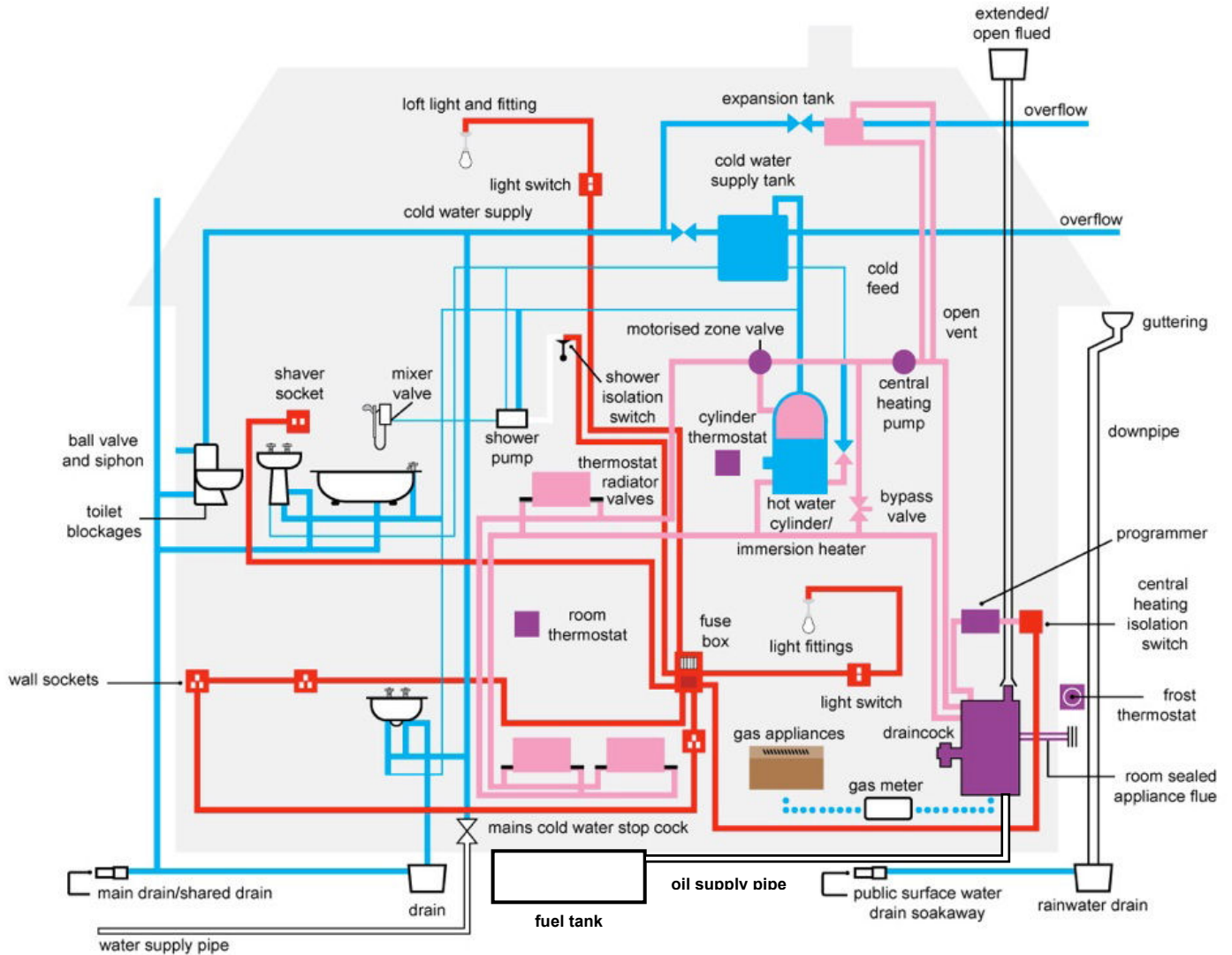

- |  |   |
|--|---|
| <span style="display: inline-block; width: 15px; height: 15px; background-color: #FFC0CB; border: 1px solid black; margin-right: 5px;"></span> Central Heating     | <span style="display: inline-block; width: 15px; height: 15px; background-color: #FF4500; border: 1px solid black; margin-right: 5px;"></span> Home Electrics                   |
| <span style="display: inline-block; width: 15px; height: 15px; background-color: #00BFFF; border: 1px solid black; margin-right: 5px;"></span> Plumbing and Drains | <span style="display: inline-block; width: 15px; height: 15px; border: 1px solid black; margin-right: 5px;"></span> Shown for reference but not included under these agreements |
| <span style="display: inline-block; width: 15px; height: 15px; background-color: #A0522D; border: 1px solid black; margin-right: 5px;"></span> Gas Appliances      | <span style="display: inline-block; width: 15px; height: 15px; background-color: #800080; border: 1px solid black; margin-right: 5px;"></span> Boiler and Controls              |
| <span style="color: blue;">.....</span> Internal Gas Supply*   |   |

\*This applies when you take out a Platinum Care Only.



## 4. Definitions used in your Terms and Conditions

Wherever the following words and phrases appear, they will have the following meaning.

**Agreement:** means each Agreement you have with us, whether a Care Agreement or a Cover Agreement.

**Annual Service:** for Agreements that include an Annual Service, means a visit we undertake in each Period of Agreement to check the elements included in your Agreement are safe and in good working order. Further details are contained in the section headed "General Conditions".

**Cover Agreement:** means our Agreements in the section headed Cover Agreements.

**Care Agreements:** means the Agreements in the section headed Care Agreements.

**Domestic Purposes:** means all the rooms in the Home must be used for normal living purposes.

**First Service:** for Agreements that require a First Service, means a visit we undertake towards the beginning of your first Period of Agreement to confirm we can accept the elements included under your Agreement. Further details are contained in the section headed "General Conditions".

**Home:** means your place of residence or a home owned by you that is a private domestic dwelling including any covered garage connected to your Home.

**Period of Agreement:** means the length of your Agreement shown on your Statement. Your Agreement begins on the date your application is accepted and normally runs for 12 months. If you add additional products to an existing Agreement, the Period of Agreement for any new products may be less than 12 months so that we can align your products so that they all renew at the same time each year.

**Our/Us/We:** means Prestige Solar and Heating Ltd for all Cover Agreements and Care Agreements.

**Power Flush:** means a product available for purchase that is designed to remove sludge and other waste from central heating systems. Further details can be found in the section headed "Other Products and Services".

**Statement:** means a written Statement you receive from us confirming the products you hold and the price for the products.

**System:** includes your expansion tank, pipework, cylinder, and radiators: Excludes fuel tanks, fuel supply pipes and water jackets on oil boilers.

**You or Your:** means the person(s) named on your Statement, together with the members of your household who normally reside with you.

## 5. General Conditions that apply to All Agreements

### 5.1 Periods of Agreement

The duration of your Agreement is shown on your Statement and will commence on the date you first applied and your application was accepted. Note that for all Care Agreements (Platinum, Gold, Silver, and Bronze) breakdowns in the first 14 days of your first year are not included.

### 5.2 Price and Price Changes

Your Agreement price is set out in your Statement and will not change during your Period of Agreement unless the Government introduces a change in the relevant tax rate. We will always write to you to tell you about any change to your price and Direct Debit instalments.

### 5.3 Payments

If you choose to pay by Direct Debit you can pay either annually or monthly. If you choose to pay annually you will incur a 3% administration charge for processing the payment. All our charges are inclusive of relevant taxes at the prevailing rate.

### 5.4 Renewals

Prior to the end of your Period of Agreement, we may write to you to tell you about any changes to what is included in your Agreement or any changes to your prices for the next year. Unless you tell us when we write to you that you do not wish to renew your Agreement for another year, we will automatically renew your Agreement for another year. If there have been no changes to what is included in your Agreement, or any changes to the prices for the next year, we will not write to you.



### **5.5 Domestic Use**

Agreements are only available for appliances and systems used inside your Home for Domestic Purposes. If you own a domestic property which you let out, you can hold our Agreements for your tenanted property.

### **5.6 Service Coverage**

There are some areas of Great Britain where we do not currently provide Agreements. If this affects you, we will tell you when you apply.

### **5.7 Our Responsibilities**

We will meet our responsibilities under your Agreement(s) within a reasonable time unless it is impossible because of circumstances outside of our control. If we are unable to meet our responsibilities, we will notify you as soon as possible confirming the reasons why we are unable to meet our responsibilities and provide you with an alternative time when we expect we can satisfy our obligations to you.

### **5.8 Boilers**

If your Agreement includes repairs to boilers: whether we installed your boiler or not, if we agree that your boiler is less than 7 years old and you have had continuous Platinum Care for 7 years or more, we will provide a suitable new replacement boiler, on the condition that you have the original Gas Safe or OFTEC Registration Certificate for your boiler. We will approve this if it is not possible to repair yours because, for example, spare parts are not available, or we decide that it would cost more to repair the boiler than to replace it. If we installed your boiler and we agree that your boiler is 7 years old or more but is less than 10 years old, and you have had continuous Platinum Care for the life of the boiler, we will provide you with a suitable new replacement boiler approved by us if it is not possible to repair yours because for example, spare parts are not available or we decided that it would cost more to repair the boiler than to replace it. Outside of these specific circumstances or any other specific circumstances specified in your Agreement, you are not entitled to a replacement boiler.

### **5.9 Gaining Access to your property and arranging appointments**

Our engineers need to be accompanied in your property always by someone aged over 18 years. It is your responsibility if a parking permit is required to provide this on the scheduled date. Please note that any cost incurred cannot be redeemed against the policy. It is your responsibility to allow us access to your property. If we cannot gain access, we will be unable to carry out the necessary work and you will need to arrange another appointment. If you do not arrange an appointment or we cannot gain access, your Agreement will continue even though we have been unable to carry out the work. If, after several attempts, you have not made an appointment or we still cannot gain access, we may write to you to let you know we have cancelled your Agreement.

### **5.10 Safety Advice**

We may advise you that permanent repairs or improvements are needed to help ensure your appliance or system works safely (for example, to comply with Gas Safety Regulations, such as upgrading your ventilation to meet current standards). If you do not follow our advice, it may mean that we are unable to fulfil all our obligations to you under your Agreement. In this case, your Agreement will continue to run unless you tell us you would like to cancel or if we cancel it (see "Your Cancellation Rights" and "Our Cancellation Rights").

### **5.11 Spare Parts**

If our engineer does not carry the spare parts needed on the day of your appointment, we use a central stock of parts carried by national wholesalers, which means we can normally get hold of most items the following working day. Otherwise, we will do all we reasonably can to find and install parts from our approved suppliers. We may use other approved parts or parts that have been reconditioned by the original manufacturer.



### **5.12 Labour**

One of our engineers will usually carry out the work. In some cases, we may authorise a suitably qualified contractor to carry out the work. All our contractors carry identity cards.

### **5.13 Guarantees**

We guarantee to make good any faulty parts and/or defective workmanship for a period of 12 months from the date we completed your repair. The rights in relation to any guarantee we give you are in addition to and do not affect your legal rights under the Consumer Rights Act 2015. You can get advice about your rights from a Citizens Advice Bureau or Trading Standards Department.

### **5.14 Moving home**

You will need to notify us as soon as possible about any change of address as you may not be covered in the event of a claim at your new property. Once we have received new address details from you for your new Home we will transfer your Agreement to this new address (unless you tell us you do not want to continue with your Agreement) and arrange a First Service for your new home (see 5.16)

### **5.15 Governing Law**

The Terms and Conditions for all Agreements are written in English and all correspondence shall be in English. Your Agreement is governed by the laws of England and Wales where your home is in England or Wales.

### **5.16 First Service**

If your Agreement includes a First Service, we will arrange to inspect your boiler and controls or oil/gas central heating system/gas appliance (depending on what is included in your Agreement), to help ensure we can include them in your Agreement and that they are safe and in good working order.

We will normally carry out your First Service within 42 days of your first Agreement, although it may be later if there is a lot of demand for our services especially in colder weather.

Our engineer will fill in a service/breakdown checklist to show you that it has been inspected. If your First Service reveals a problem (such as boilers for which we know we cannot obtain parts, or systems that are installed unsafely or are inaccessible) we may:

- a) Tell you what work is needed and what it will cost to do that work,
- b) Offer you a different product which will not include the part(s) of your system causing the problem which we are unable to include in your Agreement or
- c) Cancel your Agreement and refund any money you have paid.

We will not carry out a First Service if we have already carried out a First Service or Annual Service at the same property in the previous 12 months, irrespective of any change of ownership.

### **5.17 Annual Service**

If your Agreement includes an Annual Service, we will arrange to visit your Home in the second and subsequent years of your Agreement to inspect your boiler and controls or oil/gas central heating system (depending on what is included in your Agreement) to help ensure that they are safe and in good working order. We will normally complete your Annual Service around twelve months from the date of your last Annual Service. In periods of high demand for our services (such as cold weather), we prioritise breakdowns and may need to rearrange your Annual Service visit. If you have a breakdown in the four months before your Annual Service is due, we may complete it at the same time we visit to repair the breakdown to your system or appliance. We will not normally carry out an Annual Service if we have already carried out a First Service or Annual Service at the same property in the previous 12 months, irrespective of any change of ownership.





## 6. General Conditions – Cancellation

### 6.1 Your Cancellation Rights

You may cancel any Agreement you have with us at any time provided you notify us via email to: [info@kentsolar.uk.com](mailto:info@kentsolar.uk.com)

Or in writing to:

Prestige Solar and Heating Ltd  
10 Savage Road  
Lordswood  
Chatham  
Kent  
ME5 8DY

#### **Cancelling your Direct Debit without notifying us will not cancel your Agreement with us.**

If you cancel within the first 14 days (starting from the day after you receive written confirmation of your Agreement with us), we will give you a full refund of any money you have paid, unless we have carried out works/repairs in which case cancellation charges will apply if the contract has begun with your written agreement before the end of the cancellation period (see section 6.2)

If you cancel after the first 14 days (starting from the day after you receive written confirmation of your Agreement with us), we will give you a full refund of any money you have paid for the time left to run in your current Period of Agreement after the point of cancellation unless we have carried out works/repairs in which case cancellation charges may apply (see section 6.2)

If you wish to cancel your Agreement, we will require 28 days' notice. Please specify the date you would like your Agreement to cease considering section 6.2 of the Terms and Conditions.

### 6.2 Cancellation Charges and Waiver of 14 Day Cancellation Notice

If you cancel any Agreement you have made with us part way through your Period of that Agreement and you have had repairs/work completed in respect to that Agreement, we may charge you a contribution towards the costs we have incurred but not yet recovered. This would be less all the scheduled payments you have already made in your Period of Agreement but may be up to £500 Charge per type of repair/work completed for each repair/work completed.

You accept this Agreement subject to the Terms & Conditions herein. You understand that you have the right to cancel within 14 days of receiving this Notice. If you wish to cancel, you will provide this in writing (see section 6.1). You give Your permission for works/repairs included under your Agreement to start prior to the expiry of the statutory 14-day cancellation period. You acknowledge that if You decide to subsequently cancel the contract within the 14 days, You will be asked to pay for any works/repairs that have been carried out or goods purchased prior to Your cancellation.

### 6.3 Our Cancellation Rights

We may cancel your Agreement in the following circumstances:

- If you give us false information
- If you do not make an agreed payment
- If we receive physical or verbal abuse
- We find something wrong at a First Service
- Where there are Health and Safety issues
- Your appliance or system is not on our approved list
- You do not provide us with access to your property where required
- We are not reasonably able to find parts for your appliance or system
- Permanent repairs or improvements we tell you are required and are not completed.

If we cancel at the First Service, we will give you a full refund of any money you have paid.

If the boiler has been serviced at the First Visit for a Care Agreement, there will be a charge for the boiler service even if we are unable to offer you a Care Agreement.



If we cancel your Agreement at any time after your First Service, we will refund any money you have paid for the time left to run in your current Period of Agreement after the point of cancellation, unless we have carried out works/repairs in which case cancellation charges may apply.

#### **6.4 Cancellation of Direct Debit**

If you cancel the Direct Debit, and we have received written notification of request to cancel the Agreement, considering the notice period required (see 6.1) you will be charged a £25 administration fee in addition to an invoice for an unpaid Direct Debit which is due prior to the cessation date of the Agreement. The outstanding amount will also be subject to interest at 8.5% APR for commercial and 3% for non-commercial.

If written notification is not received (by post or email) and you cancel the Direct Debit, the initial unpaid Direct Debit will be subject to a £25 administration fee and interest at 8.5% APR for commercial and 3% for non-commercial. Subsequent unpaid Direct Debits will each be subject to a £10 administration fee and interest at 8.5% APR for commercial and 3% for non-commercial.

Interest will be charged from the date the payment became due.

Until written notification is received, these unpaid Direct Debit amounts will continue to accrue.

After a period of 90 days we will proceed to legal action without further notice.

#### **6.5 Unpaid Direct Debit when the Agreement has not been cancelled**

If we are unable to collect a Direct Debit and the Agreement has not been cancelled, each unpaid Direct Debit will be subject to a £25 administration fee. The outstanding amount will also be subject to interest at 8.5% APR for commercial and 3% for non-commercial from the date it is due.

## **7. General Exclusions that apply to all Agreements**

### **7.1 Design or existing faults**

We will not be responsible for the cost of repairs or gaining access to make repairs where there are design faults (unless we are responsible for the design faults), faults which existed before you entered your Agreement with us or faults which we could not, using reasonable care and skill, identify on our First Service of your system or appliance. For example, pipes buried under concrete floors that have been installed incorrectly or without wrapping or movement protection.

### **7.2 Accidental damage/third-party damage/damage from intentional risk taking**

The cost or repairs relating to accidental damage caused is excluded.

Where work is undertaken on your system or appliance by anyone other than Us, whether following our advice or not, which results in damage to that or another part of your system, for example because of poor workmanship, the repair of any such damage will be excluded from your Agreement.

### **7.3 Oversight**

Situations arising due to oversight or lack of proper attention from You or a third-party, including tenants (for example, filling loop not closed following topping up of system under general maintenance).

### **7.4 All other loss and damage**

Unless we cause it, we will not be responsible for any loss or damage to property (including any cleaning needed) or any other type of loss caused by the system or appliance to which your Agreement relates breaking down/failing or being accidentally damaged by you or leaking (for example, damage to fixtures/furniture caused by water leaks). If access must be made to your system or appliance, we will fill any holes and leave the surface level but we will not replace the original surface or construction. Any redecoration or repair of damage that may be needed following our work is your responsibility, unless we have been negligent.



## 7.5 Making Good

We will fill in any holes and leave the surface level where access must be made to your system or appliance, to carry out a repair, but we will not replace the original surface or construction (e.g. redecoration)

## 7.6 Risks normally insured under household or other insurances

Except and only to the extent specifically stated as being included under your Agreement, we will not include the repairing of faults or damage or replacement of appliances or systems caused by freezing weather conditions, subsidence, structural repairs, accident, fire, lightning, explosion, flood, or storm. You should check your household insurance to make sure you have enough cover for these risks.

If anything, specifically stated as being included under your Agreement is also included under any other insurance or maintenance contract you hold, the repair will be the responsibility of the provider of your other insurance or maintenance contract. In the event of joint responsibility with your other provider, we will only ever be responsible for our fair share and to the extent of our obligations under your Agreement.

## 7.7 Approved equipment

For certain items, we maintain an approved list. We only undertake work on oil/lpg/gas/electric appliances, central heating system controls, energy-management systems and plastic pipes that are on our approved list.

## 7.8 Third-party rights

Nobody other than you will be able to benefit from your Agreement, which cannot be passed to someone else without written consent.

## 7.9 Other Exclusions

We will not include the following:

- Replacing appliances, bathroom fixtures, showers, and sanitary ware except as are specifically stated as being included under your Agreement.
- Improvements including work that is needed to bring your appliance/system up to current standards/legislative requirements. You may need to have the improvements carried out before we can complete other repairs to your appliance/system.
- Upgrades which you may want to have carried out to improve your appliance/system.
- Replacing or repairing parts that do not affect how the appliance/system works or decorative or specialist parts.
- Resetting controls (for example, thermostats and programmers following changes due to winter or summer).
- General maintenance (for example, topping up central heating systems, bleeding radiators, changing batteries in heating controls)
- Removing asbestos associated with repairing the appliance/system. When you have had any asbestos removed, you must give us a clean-air certificate before we will do any further work at your property. By law, the person who removes the asbestos must give you a clean-air certificate.
- Cash alternatives for service, maintenance, or repair.
- Repairing or replacing any lead, steel, or central heating iron pipes (other than where the gas-supply pipe from meter to appliance is specified stated as being included under your Agreement).
- The cost of repairing damage or breakdowns caused by changes to, or problems with, the gas, electricity, or water services.
- Commencing and/or continuing services where we reasonably consider that there is a Health and Safety risk including, but not limited to the presence of; hazardous materials; infestations, or harassment of our personnel including verbal or physical abuse. We will not recommence work until the Health and Safety risk has been rectified to our satisfaction.
- Any costs over £1,000 (incl. VAT) to gain access to your system, built in appliance, buried pipework, or wires to make a repair and then make good (see section 7.4). We do not include the cost of getting to your appliance or system where it is inaccessible due to a design fault. Separate exclusions apply to Drains and Water Supply Pipe Repairs (see section 8.8)





### 7.10 Chargeable Visits

If a visit is booked on the assumption that it is covered by the existing Agreement, but the matter which necessitated the visit is an exclusion, You will be charged for the visit as per Our standard charges at the time of the visit.

## 8. Care Agreements

### 8.1 Bronze Care

#### (Boiler and Controls Plus Annual Service)

The following are included in your Agreement for Bronze Care

- First Service of your boiler in your first Period of Agreement and an Annual Service in subsequent Periods of Agreement for your boiler.
- Service and repairs in the event of a breakdown of a single gas or oil boiler and controls in your Home (shown in purple on the diagram 3)
- Parts and labour –if all the essential working parts are available and the appliance is on our approved list.
- Costs up to £1,000 (including VAT) we would incur to get access to your system/appliance to make a repair (For example, pipes buried in walls or “built-in” appliances) and making good.

Making good damage caused by gaining access means filling or plastering to make level but excludes any redecoration which will be your responsibility. We do not include the cost of getting to your appliance where your system is inaccessible due to a design fault. These exclusions and the General Conditions and Exclusions apply (see sections 6 and 7).

### 8.2 Bronze Care Exclusions

These exclusions and the General Conditions and Exclusions apply (see sections 6 and 7).

The following are not included in your Agreement:

- Breakdowns in the first 14 days of your first Period of Agreement are not included.
- Removing sludge or hard water scale from your system or appliance
- Repairing damage caused by scale, sludge, or other debris if we have told you on a previous visit that permanent repairs, improvements, or a Power Flush (or a similar cleaning procedure) are needed to help ensure your appliance/system works properly.
- Repairing or replacing appliance flues other than room sealed appliance flues (up to 1m in length). This does not include flue terminals that are not part of the flue system.
- Repairing or replacing appliance flues that aren't part of your boiler.
- Servicing and maintenance of electric boilers.
- Oil tanks and oil supply pipes.
- Any costs over £1,000 (including VAT) we would incur to get to your system/appliance to make a repair. For example, pipes buried in walls or “built-in” appliances plus making good. We do not include the cost of getting to your appliance where your system is inaccessible due to a design fault.

### 8.3 Silver Care

#### (Boiler and Controls, Annual Service Plus Central Heating)

This Care Agreement is designed to meet the demands and needs of householders who want protection in place in the event of various problems with their boiler and controls, and central heating on a repair and maintenance basis, including Annual Service.

All the benefits of Bronze Care plus:

- Service and repairs in the event of breakdown of a single wet central heating (using water) or warm air gas central heating system in your Home or an electric (repairs only) and solar thermal system if we installed it. Warm air vents are covered for warm air units only (shown in pink in section 3)



#### 8.4 Silver Care Exclusions

The exclusions below, the exclusions for Bronze Care and the General Conditions and General Exclusions apply (see sections 6 and 7).

The following are not included in your Agreement:

- Repairing or replacing parts of your central heating system and controls that are specifically designed for piped or electric underfloor heating (other than warm air systems)
- Any costs over £1,000 (including VAT) we would incur to get to your system/appliance to make a repair. For example, pipes buried in walls or "built-in" appliances plus making good. We do not include the cost of getting to your appliance where your system is inaccessible due to a design fault.
- Costs over £1,000 (including VAT) per claim

Making good damage caused by gaining access means filling or plastering to make level but excludes any redecoration which will be your responsibility. We do not include the cost of getting to your appliance where your system is inaccessible due to a design fault.

#### 8.5 Gold Care

##### **(Boiler and Controls, Annual Service, Central Heating Plus Internal Plumbing and Internal and External Drains)**

All the benefits of Bronze & Silver Care plus the following:

- Repairs or replacement inside your Home and to fixed external pipes if supplying water from your Home in the event of leaks or mechanical failure (shown in blue in section 3).
- Hot and cold water pipes from the mains stopcock inside your Home leading to your taps and garden taps (but not including the mains stopcock and taps themselves).
- Your cold-water storage tank
- Leaking overflow pipes
- Standard ball valves and toilet siphon
- Pipes that burst because of cold weather
- Central heating water pipes if there is a water leak
- Radiator valves
- Hot water cylinders and immersion heaters
- Washing machine and dishwasher hot and cold flexible pipes (if they are installed to the Manufacturers' instruction)
- Parts and Labour for fitting standard replacement parts. Standard replacement parts may differ from the original, for example, using a standard flush handle to replace a gold plated flush handle, unless you provide an alternative.
- Costs up to £1,000 (including VAT) we would incur to get access to your system/appliance to make a repair, (for example, pipes buried in walls or "built-in" appliances) and making good.
- Restoring flow by getting to and unblocking or repairing drainage pipes and waste pipes for example, unblocking sinks, waste, and rainwater drains. This applies to pipes within the boundary of your property but only where you have the sole responsibility for the pipes (this does not include public or shared drains even if these are within the boundary of your property).
- Parts and Labour are included up to £1,000 (including VAT) per claim to access your system and make repairs.
- Maintenance inspection to check for water leaks on your internal pipework, valves, and hot water cylinder. We will provide your Maintenance Inspection at the same time as your Annual Service for your boiler and central heating system.

#### 8.6 Gold Care Exclusions

The exclusions below, the exclusions for Bronze and Silver Care and the General Conditions and General Exclusions apply (see sections 6 and 7).

The following are not included in your Agreement:

- Replacing ceramic discs in taps unless we can replace from the limited van stock range our engineers carry
- Replacing or repairing taps
- Bath and Shower seals/grouting



- Repairing or replacing the mains cold water stopcock, water softeners, shower pumps and mixer valves, combined overflow and pop up waste mechanism, mechanical pumps, water filters, radiators, swimming pools, decorative garden features, rainwater pipes and guttering, waste disposal units, macerators such as Saniflo, and electrical units for toilets.
- Costs over £1,000 (including VAT) per claim
- Any costs over £1,000 (including VAT) we would incur to get to your system/appliance to make a repair, for example, pipes buried in walls or "built-in" appliances plus making good. We do not include the cost of getting to your appliance where your system is inaccessible due to a design fault.
- Repair and replacement of lead and steel pipes
- Temporarily frozen pipes which have not resulted in confirmed damage
- Pipes that burst because of cold weather where we have previously advised that insulation is required.
- Repairing or unblocking drains shared with another property or properties that are the responsibility of your water company.
- Repairing or replacing manholes, soakaways, septic tanks, cesspits, treatment plants and their outflow pipes
- Regularly cleaning your drains and any de-scaling of your drains.
- Repairing or unblocking drains outside the boundary of your property
- Repairing or unblocking drains which are used for mainly commercial purposes
- Making access to drain systems points of entry (such as manhole covers) where these have been built over.

Making good damage caused by gaining access means filling or plastering to make level but excludes any redecoration which will be your responsibility. We do not include the cost of getting to your appliance where your system is inaccessible due to a design fault.

### **8.7 Platinum Care**

#### **(Boiler and Controls, Annual Service, Central Heating, Internal Plumbing and Internal and External Drains plus Home Electrics)**

All the benefits of Bronze, Silver, and Gold Care plus the following:

- Repairs of electrical wiring and electrical fixtures inside your home and within outbuildings if the outbuildings do not contain their own power supply and the wiring and fixtures have been installed correctly. This covers the fixed electrical wiring system and fuse boxes, light switches, wall sockets, circuit breakers and transformers (shown in red in section 3)
- Parts and labour are included for fitting standard replacement parts, for example, we will replace all fittings with our nearest equivalent standard white plastic unless you supply an alternative.
- Rodent damage to wiring (property must not be unoccupied for a continuous period of 4 weeks or more) once the customer has provided a certificate from a professional extermination company to prove the property is no longer infested.
- Costs up to £1,000 (including VAT) we would incur to get access to your system/appliance must make a repair, (for example, pipes buried in walls or "built-in" appliances) and making good.
- Repairs to all gas supply pipework inside your Home, between your meter and any gas appliance included in your Agreement(s).
- Repairs following breakdowns to your Solar Photovoltaic panels and system if installed by us.
- Maintenance Inspection at your request once in every two-year continuous Period of Agreement.

Making good damage caused by gaining access means filling or plastering to make level but excludes any redecoration which will be your responsibility. We do not include the cost of getting to your appliance where your system is inaccessible due to a design fault. These exclusions and the General Conditions and Exclusions apply (see sections 6 and 7).

### **8.8 Platinum Care Exclusions**

The exclusions below, the exclusions for Bronze, Silver and Gold Care, and the general exclusions apply (See sections 6 and 7)



The following are not included in your Agreement:

- Repairing detectors.
- Repairing or replacing the mains supply up to the fuse box.
- Repairing the parts of the power supply between your home and the outbuildings on your property that are outside of the buildings.
- Repairing or replacing rubber or lead wiring.
- Repair of accidental damage
- Repair of accidental damage to the main electrical consumer unit or fuse box.
- Damage to or replacement of Solar Photovoltaic Panels and installations caused by risks normally covered under household or other insurances (see General Exclusions sections 6 and 7)
- Costs over £1,000 (including VAT) per claim
- Any costs over £1,000 (including VAT) we would incur to get to your system/appliance must make a repair, (for example, pipes buried in walls or "built-in" appliances) and any making good. We do not include the cost of getting to your appliance where your system is inaccessible due to a design fault. Making good damage caused by gaining access means filling or plastering to make level but excludes any redecoration which will be your responsibility. We do not include the cost of getting to your appliance where your system is inaccessible due to a design fault. These exclusions and the General Conditions and Exclusions apply (see sections 6 and 7).

## 9. Service Only Cover

The following is included in your Agreement:

- Annual Service for gas appliances e.g. boilers, fires, water heaters, wall heaters and cookers in your Home, or Annual Service for your oil boiler. Each of your appliances included in your Annual Service will be specified in your Statement.

### 9.1 Service Only Cover Exclusions

- This Agreement does not include any repairs. You can choose to have extra work done, but you must pay for the parts (if available) and labour.
- Repairing or replacing appliance flues that aren't part of your boiler.
- Any costs over £1,000 (including VAT) we would incur to get to your system/appliance must make a repair, for example, pipes buried in walls or "built-in" appliances plus making good. We do not include the cost of getting to your appliance where your system is inaccessible due to a design fault.

Making good damage caused by gaining access means filling or plastering to make level but excludes any redecoration which will be your responsibility. We do not include the cost of getting to your appliance where your system is inaccessible due to a design fault. These exclusions and the General Conditions and Exclusions apply (see sections 6 and 7).

## 10. Home Electrics Cover

The following are included in your Agreement:

- Repairs of electrical wiring and electrical fixtures inside your home and within outbuildings if the outbuildings do not contain their own power supply and the wiring and fixtures have been installed correctly. This covers the fixed electrical wiring system, fuse boxes, light switches, wall sockets, circuit breakers and transformers.
- Parts and labour are included for fitting standard replacement parts, for example, we will replace all fittings with our nearest equivalent standard white plastic unless you supply an alternative.
- Rodent damage to wiring (property must not be unoccupied for a continuous period of 4 weeks or more) once the customer has provided a certificate from a professional extermination company to prove the property is no longer infested.
- Costs up to £1,000 (including VAT) we would incur to get access to your system/appliance to make a repair, (for example, pipes buried in walls or "built-in" appliances) and making good.
- Repairs following breakdowns to your Solar Photovoltaic panels and system if installed by us.



Making good damage caused by gaining access means filling or plastering to make level but excludes any redecoration which will be your responsibility. We do not include the cost of getting to your appliance where your system is inaccessible due to a design fault. These exclusions and the General Conditions and Exclusions apply (see sections 6 and 7).

### 10.1 Home Electrics Cover Exclusions

The following are not included in your Agreement:

- Repairing controls, pumps, detectors, timers, and programmers.
- Repairing or replacing the mains supply up to the fuse box.
- Repairing the parts of the power supply between your home and the outbuildings on your property that are outside of the buildings.
- Repairing or replacing rubber or lead wiring.
- Repair of accidental damage.
- Repair of accidental damage to the main electrical consumer unit or fuse box.
- Damage to or replacement of Solar Photovoltaic Panels and installations caused by risks normally covered under household or other insurances (see General Exclusions sections 6 and 7)
- Any costs over £1,000 (including VAT) we would incur to get to your system/appliance to make a repair, (for example, pipes buried in walls or "built-in" appliances) and any making good. We do not include the cost of getting to your appliance where your system is inaccessible due to a design fault.

Making good damage caused by gaining access means filling or plastering to make level but excludes any redecoration which will be your responsibility. We do not include the cost of getting to your appliance where your system is inaccessible due to a design fault. These exclusions and the General Conditions and Exclusions apply (see sections 6 and 7).

## 11. Landlord Assistance

Landlords can purchase any of our Care Agreements and can also purchase the following additional Cover services for their tenanted properties.

### 11.1 Landlord Gas Safety Certificate Cover

By law, Landlords must have gas appliances in properties they let checked for safety every 12 months. They should also hold a Gas Safety Record as proof. A Landlord Gas Safety Certificate is an annual one off inspection available for gas appliances.

The following are included with your Landlord Gas Safety Certificate Cover:

- A one-off inspection available for Gas boilers, fires, and cookers.
- A Gas Safety Record.

Landlords can choose to purchase:

- Landlord Gas Safety Certificate Cover (charge covers two appliances in any one property).
- Gas Safety Certificate for individual appliances added to a Care Plan (charges are per appliance)
- Gas Safety Certificate Cover combined with Service Only Cover.

Landlords, who purchase the Gas Safety Certificate Cover and Service Only Cover, will receive their Gas Safety Certificate at the same time we carry out their Annual Service.

### 11.2 Landlord Gas Safety Certificate Cover Exclusions

- This Agreement does not include any repairs. You can choose to have extra work done, but you must pay for the parts (if available) and labour.
- Repairing or replacing appliance flues that aren't part of your boiler.
- If service only cover is purchased for the boiler but Landlord Gas Safety Certificate Cover has been purchased for two appliances, the Annual Service Certificate will be issued for the boiler only whilst the Landlord Gas Safety Certificate will cover the boiler and one other gas appliance at the property.
- Any costs over £1,000 (including VAT) we would incur to get to your system/appliance to make a repair, for example, pipes buried in walls or "built-in" appliances plus making good.





We do not include the cost of getting to your appliance where your system is inaccessible due to a design fault.

Making good damage caused by gaining access means filling or plastering to make level but excludes any redecoration which will be your responsibility. We do not include the cost of getting to your appliance where your system is inaccessible due to a design fault. These exclusions and the General Conditions and Exclusions apply (see sections 6 and 7).

### 11.3 Landlord Electrical Inspection (LEI)

The following are included with your LEI:

- A one-off visual safety inspection of electrical wiring and electrical fixtures.
- An Electrical Inspection Certificate.

### 11.4 Landlord Electrical Inspection Cover Exclusions

- This Agreement does not include any repairs. You can choose to have extra work done, but you must pay for the parts (if available) and labour.
- Any costs over £1,000 (including VAT) we would incur to get to your system/appliance to make a repair, for example, pipes buried in walls or "built-in" appliances plus making good. We do not include the cost of getting to your appliance where your system is inaccessible due to a design fault.

Making good damage caused by gaining access means filling or plastering to make level but excludes any redecoration which will be your responsibility. We do not include the cost of getting to your appliance where your system is inaccessible due to a design fault. These exclusions and the General Conditions and Exclusions apply (see sections 6 and 7).

## 12. Care and Cover Agreements

All Care and Cover Agreements are Agreements for services provided by Prestige Solar and Heating Ltd.

### 12.1 Similar Services

Prestige Solar and Heating Ltd may introduce Agreements that provide similar services and additional benefits to those that are currently being provided to you under your Care and/or Cover Agreement(s). If you pay by Direct Debit you hereby request and confirm that at the next anniversary of your Care and/or Cover Agreement(s) we may arrange those Agreements for you and then renew them annually until you notify us otherwise. You can call us anytime on 0800 4087 911 if you would prefer to revert to your Care and/or Cover Agreement(s).

## 13. Using personal information (applicable to all Agreements)

We or our agents may use information about you to do the following:

- Provide you with the services you have requested (which may include loyalty and incentive schemes we may run from time to time).
- Offer you accounts, services and products from time to time from us and our partners. To help us make these offers we may use an automatic scoring system, which also uses information about you from other credit reference agencies, as well as other companies.
- Help run, and contact you about improving the way we run, any accounts, services, and products we have provided before, now or in the future.
- Create statistics, test computer systems, analyse customer information, create profiles, and create marketing opportunities (including using information about what you buy from us and how you pay for it).
- Help to prevent and detect debt, fraud, or loss
- Help to train our staff; and
- Contact you in any way (including by post, email, phone, text or multimedia messages or other forms of electronic communications, or by visiting you) about products and services we and our partners are offering.

When we contact you, we may use any information we hold about you to do so. We may contact you by email, phone, text message or other forms of electronic communication or by visiting you. If we are



contacting you to tell you about any offers, we will, as far as possible, do this in line with how you have told us you would prefer to receive marketing information. You can ask us not to send you any information on our offers at any time by contacting us and giving us your account details.

We may allow other people and organisations to use information we hold about you:

- To provide services you have asked for, which may include providing information to members of your family or household, anyone acting on your behalf or other people who may be interested (such as landlords or letting agents).
- As part of the process of selling one or more of our businesses
- To help to prevent and detect debt, fraud, or loss (for example by giving this information to a credit-reference agency) which is described in more detail below
- If you do not pay your debt, we may transfer your debt to another organisation and give them details about you and that debt
- If we have been asked (for example by Ofgem or a lawyer) to provide information for legal or regulatory purposes
- As part of current or future legal action
- As part of Government data-sharing initiatives; for example, those designed to stop fuel poverty (where people cannot afford to pay for heating and electricity)
- To help manage any loyalty or rewards schemes
- If you hold an insurance policy, to pass information to an insurer to assist your insurance policy (including underwriting and claims, to help develop new services and to assess financial and insurance risk). We may also monitor and record any communications we have with you including but not limited to phone conversations and emails, to make sure that we are providing a good service and to make sure we are meeting our legal and regulatory responsibilities.

If we suspect someone has committed fraud or stolen energy by tampering with the meter or diverting the energy supply, we will record these details on your account record and may share this information with Ofgem and other people who are interested (such as the energy suppliers, landlords and housing associations). We may use this information to make decisions about you, your character, how likely we think you are to pay for your Care and/or Cover Agreements. This may include recording sensitive personal information such as criminal offences you have been accused of. Also, if the gas or electricity supply to your property has previously been tampered with or if gas or electricity has been stolen, or we suspect it has been stolen, we may take this into account when we decide what products or services we can offer you and the Terms and Conditions we give you.

We may pass your address, property and postcode, and details of your gas appliances, flue, hot water cylinder, system controls and electrical installations (including details of any repairs or removals), to organisations that supervise these activities including but not limited to Gas Safe (previously Corgi), the ECA (Electrical Contractors Association) and OFTEC. These organisations may pass this information to local authorities to meet building regulations. They may also use this information to contact you to inspect appliances or systems, recall faulty products and carry out audits, and for Health and Safety purposes. Where appropriate, we will give you, or the property owner (or both), a certificate to show that your appliances meet building regulations.

We may check your details with one or more credit reference and fraud-prevention agencies to help us make decisions about your ability to make payments and the goods and services we can offer you. Below we have given a brief guide to how we, the credit-reference and fraud-prevention agencies will use your information.

We may search at credit-reference and fraud-prevention agencies for information about you and all the people you are applying with. If you are providing information about other people on a joint application, you must make sure they agree that we can use their information to do this. If you give us false or inaccurate information and fraud is identified, we will pass your details to credit-reference and fraud-prevention agencies. Law enforcement agencies (such as the Police and HM Revenue and Customs) may receive and use this information.

We and other organisations may also access and use information about you that credit-reference and fraud-prevention agencies give us to, for example:

- Check details on applications you make for credit and credit-related services
- Check your identity
- Prevent and detect fraud and money laundering



- Manage credit and credit-related accounts or services
- Recover debt
- Check details on proposals and claims for all types of insurance
- Check details of employees and people applying for jobs with us.

When credit-reference agencies receive a search from us, they will record this on your credit file; whether your application is successful or not. We will send information on your account to credit reference agencies and they will record it if you have an account with us, we will give details of it and how you manage it to credit-reference agencies.

If you have an account and do not repay money you owe in full or on time, credit-reference agencies will record this debt. They may give this information to other organisations and fraud prevention agencies to carry out similar checks, find out where you are and deal with any money you owe. The credit-reference agencies keep records for six years after your account has been closed, you have paid the final debt or action has been taken against you to recover the debt.

We and other organisations may access and use, from other countries, information recorded by fraud-prevention agencies. If you want to see what information credit-reference and fraud-prevention agencies hold about you, you can contact the following agencies currently working in the UK. The information they hold may not be the same, so it is worth contacting them all. They will charge you a small fee.

Call Credit [www.callcredit.co.uk](http://www.callcredit.co.uk)  
Equifax plc [www.myequifax.co.uk](http://www.myequifax.co.uk)  
Experian [www.experian.co.uk](http://www.experian.co.uk)

If you give us information on behalf of someone else, you can confirm you have given them the information set out in this document, and that they have given permission for us to use their personal information in the way we have described in this section. If you give us sensitive information about yourself or other people (such as health details or details of any criminal convictions or members of your household), you agree (and confirm that the person the information is about has agreed) that we can use this information in the way set out in this document.

You are entitled to have a copy of the information we hold on you and to have any inaccurate information corrected.

We may charge a small fee for providing a copy of any information we hold about you. For more information about this please contact us at;

Prestige Solar and Heating Ltd  
10 Savage Road  
Lordswood  
Chatham  
Kent  
ME5 8DY

Or email us at: [info@kentsolar.uk.com](mailto:info@kentsolar.uk.com)  
Or contact us via our website: [www.kentsolar.uk.com](http://www.kentsolar.uk.com)  
Or telephone us on: 0800 4087 911

The privacy act also extends to spouses, partners and family that are not named on this Agreement.

## 14. Other products and services

### 14.1 Power Flush

You can purchase a Power Flush to remove sludge and other waste from your central heating systems. Once you have purchased a Power Flush from us, there will be no charge for any future Power Flush work that may be needed, providing you keep a continuous Platinum Care Agreement at that property.

### 14.2 System filters and scale reducers

You can purchase system filters and scale reducers. Once we have installed them, there will be no charge for any future system filter work that may be needed, providing you keep a continuous Care



Agreement at that property. As part of any Annual Service, if necessary, we will also clean the filter on any system filter you have had installed, whether we installed it or not.

### 14.3 Condensate pipe kits

You can purchase Trace Heater kits/frost protection to help protect your condensate pipe from freezing over. Once we have installed them there will be no charge for any future Trace Heater kits/frost protection that may be needed, providing you keep a continuous Care Agreement at that property. Separate Terms and Conditions apply to the products and services in this section 14.

## 15. Frequently asked questions

**Q. My boiler, appliance or system is old. Does my Care Agreement still cover me?**

A. There is no age limit on your boiler, appliance or system and it does not matter who installed it; providing all the essential working parts are available. If some parts are not available, we will let you know.

**Q. Why do your engineers recommend changes to my system?**

A. Our engineers are highly qualified and up to date with the latest technology and legislation. If they identify a possible change to your system they will only recommend this if, in their expert opinion, it is necessary.

**Q. What do "Upgrades to my system" mean?**

A. Upgrades are changes to your system which will improve its efficiency or safety. Examples of upgrades are replacing working radiators with improved models, replacing standard radiator valves with thermostatic radiator valves, Power Flush, and system filters. Upgrades are not included in your Agreement.

**Q. I need a new boiler. Do I receive any benefits by being a Care Agreement customer?**

A. Yes, as a Care Agreement customer with a boiler or central heating Agreement you are entitled to a special offer on installing a new boiler, if Prestige Solar and Heating Ltd install it.

**Q. My pipes seem to be frozen. Can you offer any advice to fix these?**

A. You can usually decrease the thaw time by applying gentle heat to the frozen area. Wrapping hot towels around the pipework can be effective, or adding an extra non-direct heat source to the area containing the frozen pipes. Be aware that applying too much direct heat, such as a blow torch or a naked flame can cause damage to the pipework or surrounding area, and could create a fire risk; therefore, this method of thawing must be avoided. Care should also be taken where electrical appliances (fan heaters etc.) are used to heat the area. Do not use where there is a risk of flooding or contact with water. Please see our common problem page on our website; [www.kentsolar.uk.com](http://www.kentsolar.uk.com)

**Q. How will I know what the engineer has done at my First Service, Annual Service, or breakdown?**

A. Our engineer will fill in a digital checklist which is kept at our main head office and can be emailed to you upon request. The engineer will explain this to you and will answer any questions you may have.

**Q. My new Agreement includes a First Service. When will this take place?**

A. We aim to carry out this service within 42 days from the beginning of your Agreement. However, as we give priority to breakdowns, on occasions it can be later if there is a high demand for our services, especially in colder periods.

**Q. I think my Annual Service is due but I have not heard from you?**

A. On or around the anniversary date of your last Annual Service we will contact you in writing, email or by telephone to arrange a suitable appointment. On occasions this may happen earlier or later than you expect, if there has been or if we anticipate there will be, a high demand for breakdown repairs.

**Q. I have a problem with my boiler, but I still have heating. How quickly will the engineer get to me?**

A. Demand for repairs goes up sharply when it is colder and we cannot always accurately predict when this will be. This means we cannot always get to everyone as quickly as we would like. In these circumstances, we prioritise customers based on the severity of their problem and how vulnerable they may be to being without heating or hot water.

**Q. Why doesn't the engineer have the necessary part to fix my problem?**

A. Our engineers carry a van stock of the most commonly used parts in your area. Unfortunately, with the vast range of boilers and subsequent parts available, it is not possible to carry all the parts that



might be required. If a part is not available on the van, we aim to get what is required to the engineer as soon as possible and in most cases for the next day.

**Q. Can my Annual Service be done at the same time as a repair, and vice versa?**

A. Yes, if you have a problem which you want us to look at during your Annual Service let us know when you arrange your appointment so that we can ensure the engineer has enough time to do both. If you need a repair and your Annual Service is due we will ask if we can do both in the same visit. Many of our customers find this is more convenient.

**Q. Why has my price changed from last year?**

A. In the first year of your Agreement we have limited information about your boiler, system, and usage so your price is based on our average costs. In subsequent years, we have much more detailed and accurate information about your boiler and system which means the price we charge is tailored to you. This means we can be fairer in our pricing, by charging less for customers who rarely have a breakdown, have a smaller property or a boiler which is cheaper to maintain and more for customers who have frequent breakdowns and boilers which are costly to maintain.

**Q. In what circumstances would you suspend or cancel my Agreement?**

A. If we encounter hazardous materials or infestations we would suspend or cancel your Agreement until the Health and Safety risk is resolved to our satisfaction. If we encounter physical or verbal abuse, we would suspend or cancel your Agreement.

## 16. Complaints

We will always aim to do our best, but unfortunately there may be times when things go wrong. If you have a complaint about any part of our service or your products, please write to us at:

Prestige Solar and Heating Ltd  
10 Savage Road  
Lordswood  
Chatham  
Kent  
ME5 8DY

Or email us at: [info@kentsolar.uk.com](mailto:info@kentsolar.uk.com)  
Or contact us via our website: [www.kentsolar.uk.com](http://www.kentsolar.uk.com)  
Or call us on: 0800 4087 911

We will try to deal with the matter immediately but if we cannot then we will keep you regularly informed about the progress of our investigation. If you are unhappy with our final response, or if we have not been able to complete our investigation within 8 weeks of us receiving your complaint, you may wish to take the matter further. Where we cannot resolve complaints using our own complaints procedure, as a Which? Trusted trader we use Ombudsman Services Ltd for dispute resolution. In the unlikely event of a complaint arising and you wish to refer the complaint to them please contact Which? Trusted traders in the first instance on 0117 981 2929. For full details of our Customer Complaints Handling Policy visit our website at: [www.kentsolar.uk.com](http://www.kentsolar.uk.com)





## Acceptance of Terms and Conditions of Care/Cover Agreement

Please complete this form and return to us at:

**Prestige Solar and Heating Ltd**  
10 Savage Road  
Lordswood  
Chatham  
Kent  
ME5 8DY

Or email the completed form to:

[info@kentsolar.uk.com](mailto:info@kentsolar.uk.com)

As the person(s) named on the Statement, I/we confirm that I/we have read and understand the Terms and Conditions of the Agreement

Name (print): .....

First Line of Your Address and Postcode: .....

.....

First Line of Address to which Agreement pertains: As above OR see below (delete as appropriate)

.....

Signature(s): .....

.....

Date: .....

<b>Office Use Only</b>	
Date Received: .....	
Customer ID: .....	
Smart Debit Ref: .....	T&C 1.8